

# assignment5

full credit by June 18, 2026, 11:59:00 PM CST, closes June 21, 2026, 11:59:00 PM CST

(E24126385)

Section: 1142\_E227020\_2

This PDF is available for convenience. Assignments must be submitted within **WeBWorK** for credit.

### Problem 1. (1 point)

Design a feedback amplifier to have an ideal closed-loop gain of 18 and to have an amount of feedback of at least 58 dB.

What is the required value of  $\beta$ ? \_\_\_\_\_ (V/V)

What is the minimum required value of the open-loop gain  $A$ ? \_\_\_\_\_ (V/V)

What is the corresponding realized value of closed-loop gain  $A_f$ ? \_\_\_\_\_ (V/V)

Correct Answers:

- 0.05556
- $1.428 \times 10^4$
- 17.98

### Problem 2. (1 point)

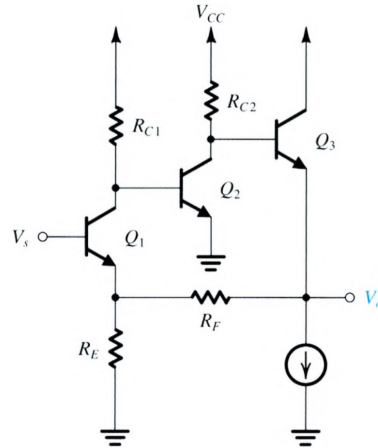

The figure shows a series-shunt feedback amplifier without details of the bias circuit.

(a) If  $R_E$  is selected to be  $49\Omega$ , find the value for  $R_F$  that results in a closed-loop gain with an ideal value of  $14V/V$ .

(b) If  $Q_1$  is biased at  $0.6mA$ ,  $Q_2$  is at  $0.9mA$ ,  $Q_3$  is at  $6.5mA$ , and assuming that the transistors have  $\beta = 100$  and larger  $r_o$ , and that  $R_{C1} = 2.5k\Omega$  and  $R_{C2} = 1.4k\Omega$ , find the value of the loop gain  $A\beta$  and hence of the closed-loop gain  $A_f$ .

$R_F =$  \_\_\_\_\_  $\Omega$   
 $A\beta =$  \_\_\_\_\_  $V/V$   
 $A_f =$  \_\_\_\_\_  $V/V$

Correct Answers:

- 637
- 52.69
- 13.74

**Problem 3. (1 point)**

Below shows a three-stage feedback amplifier:

$A_1$  has an  $84\text{k}\Omega$  differential input resistance, a  $20\text{V/V}$  open-circuit differential voltage gain, and a  $4\text{k}\Omega$  output resistance.

$A_2$  has a  $6\text{k}\Omega$  input resistance, a  $21\text{mA/V}$  short-circuit transconductance, and a  $18\text{k}\Omega$  output resistance.

$A_3$  has a  $23\text{k}\Omega$  input resistance, unity open-circuit voltage gain, and a  $1\text{k}\Omega$  output resistance.

The feedback amplifier feeds a  $1\text{k}\Omega$  load resistance and is fed by a signal source with a  $8\text{k}\Omega$  resistance.

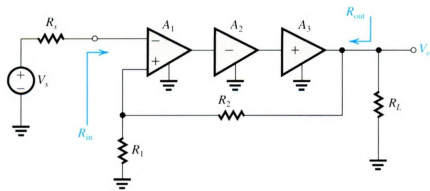

(a) If  $R_1 = 16\text{k}\Omega$ , Find the value of  $R_2$  that results in an ideal closed-loop gain of  $5\text{ V/V}$ .

$R_2 = \underline{\hspace{2cm}}\text{ k}\Omega$

(b) Find the value of the open-loop gain  $A \equiv V_o/V_s$ .

$A = \underline{\hspace{2cm}}\text{ V/V}$

(c) Find the feedback factor  $\beta$  and the amount of feedback.

$\beta = \underline{\hspace{2cm}}\text{ V/V}$

Amount of feedback  $(1 + \beta A) = \underline{\hspace{2cm}}$

(d) Find the closed-loop gain  $A_f$ .

$A_f = \underline{\hspace{2cm}}\text{ V/V}$

(e) Find the feedback amplifier's input resistance  $R_{in}$ .

$R_{in} = \underline{\hspace{2cm}}\text{ M}\Omega$

(f) Find the feedback amplifier's output resistance  $R_{out}$ .

$R_{out} = \underline{\hspace{2cm}}\text{ }\Omega$

(g) If the high-frequency response of the open-loop gain  $A$  is dominated by a pole at  $100\text{Hz}$ , what is the upper 3-dB frequency of the closed-loop gain.

$f = \underline{\hspace{2cm}}\text{ kHz}$

(h) If for some reason  $A_1$  is drops to half its nominal value, what is the absolute percentage change in  $A_f$ ?

Absolute Percentage change =  $\underline{\hspace{2cm}}\%$

*Correct Answers:*

- 64
- 1013
- 0.2
- 203.7
- 4.975
- 21.34
- 2.445
- 20.37
- 0.4885

---

**Problem 4. (1 point)**

For the feedback transconductance amplifier shown in Fig. 4, evaluate the closed-loop transconductance gain  $A_f$  and the output resistance with feedback  $R_{of}$ .

$$g_{m1} = g_{m2} = 4 \text{ mA/V}, \quad R_D = 20 \text{ k}\Omega, \quad r_{o2} = 20 \text{ k}\Omega,$$
$$R_F = 100 \text{ }\Omega, \quad R_L = 1 \text{ k}\Omega.$$

For simplicity, neglect  $r_{o1}$ , and take  $r_{o2}$  into account only when calculating the output resistance.

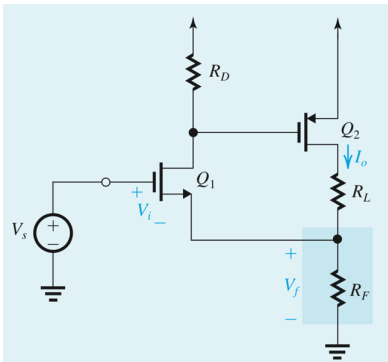

Find  $A_f$  in mA/V:

$$A_f =$$

\_\_\_\_\_ mA/V

Find  $R_{of}$  in k $\Omega$ :

$$R_{of} =$$

\_\_\_\_\_ k $\Omega$

*Correct Answers:*

- 9.581
- 503.4

**Problem 5. (1 point)**

In recent years, AI servers have needed to transmit large amounts of digital data between chips, modules, and systems. As a result, high-speed wireline transmission has become increasingly important. Although digital signals look like square waves composed of 0 and 1 in the time domain, they actually contain many high-frequency components in the frequency domain, as shown by the sinc-shaped spectrum in the figure.

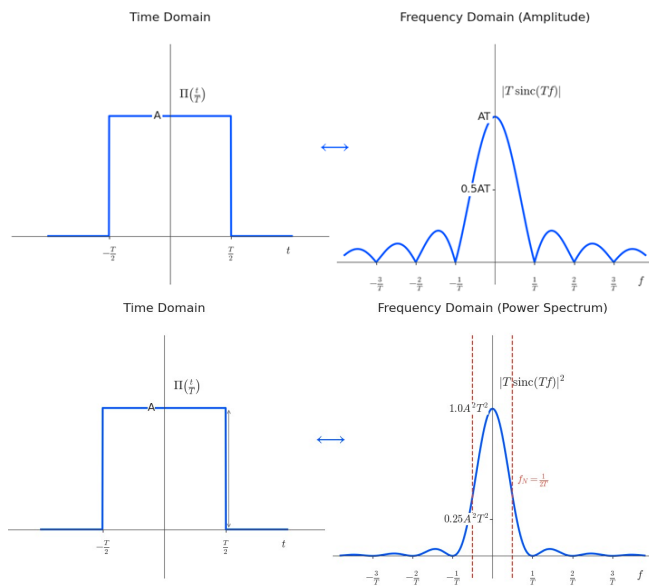

As the transmission speed increases, the symbol period ( $T$ ) becomes shorter, requiring higher circuit bandwidth. If the bandwidth is insufficient, high-frequency components are attenuated, causing waveform distortion and making data detection harder. Therefore, feedback is important in high-speed receiver circuits because it can extend bandwidth and stabilize the frequency response.

Therefore, in a high-speed wireline transmitter or receiver, the Nyquist frequency is an important bandwidth reference. If the symbol period is  $T$ , the Nyquist frequency is

$$f_N = \frac{1}{2T}$$

If we want to transmit data at a rate of 50 Gb/s. This means that a binary signal, either 0 or 1, is transmitted  $50 \times 10^9$  times per second. What is the Nyquist frequency?

Nyquist frequency = \_\_\_\_\_ GHz

Assume all transistor operate in saturation in all of the problems.

In a high-speed wireline receiver, the input signal is often a small AC current. A transimpedance amplifier, or TIA, is used to convert this input current into an output voltage.

The circuit contains an amplifier  $A_1$ , a feedback resistor  $R_F$ , and an input capacitance  $C_X$  at node  $X$ . The feedback resistor samples the output voltage and feeds a current back to the input node. Therefore, this is a shunt-shunt feedback circuit.

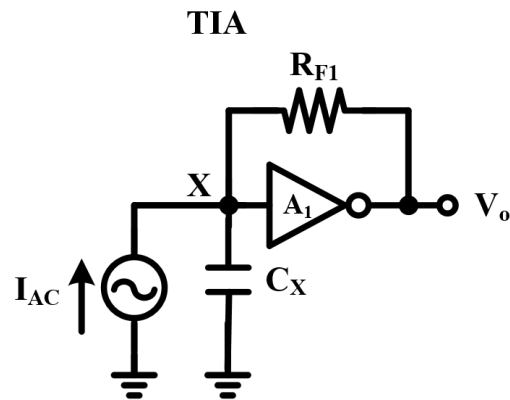

Assume:

$$R_F = 1.54k\Omega$$

$$C_X = 155.1fF$$

The amplifier  $A_1$  is modeled as an ideal amplifier:

Gain is 20 V/V

$$\text{Transfer Function is } \frac{V_o}{I_{AC}} = \frac{A_0}{1 + \frac{s}{\omega_p}}$$

$$\omega_p = \text{_____ rad/s}$$

$$|A_0| = \text{_____ V/A}$$

Problem: Source Degeneration as Local Feedback

A common-source amplifier uses a source degeneration impedance  $Z_S$ , as shown in the figure. Source degeneration is a form of local negative feedback.

When the gate voltage increase then the drain current  $i_d$  increases, the source voltage  $v_s$  also increases. Since

$$v_{gs} = v_{in} - v_s$$

an increase in  $v_s$  reduces  $v_{gs}$ . As a result, the drain current is reduced. Therefore, the circuit feeds back a signal that opposes the original current change. This is why source degeneration is called local negative feedback.

### CS Amplifier With Source Degeneration

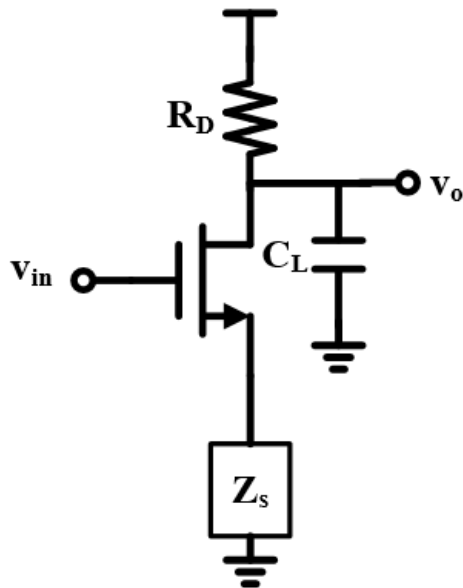

$$g_m = 38.5\text{mS}$$

$$Z_s = 1.39\text{k}\Omega$$

By what factor does source degeneration increase the bandwidth of a CS amplifier compared with the case without source degeneration?

factor = \_\_\_\_\_

A CTLE, or continuous-time linear equalizer, is commonly used in high-speed wireline receivers. In wireline channels, high-frequency signal components are usually attenuated more than low-frequency components. This causes slower signal transitions, waveform distortion.

The CTLE helps solve this problem by boosting the high-frequency components of the received signal. In this circuit,  $R_S$  provides source degeneration at low frequency, which reduces the gain. At high frequency,  $C_S$  becomes a short circuit and bypasses ( $R_S$ ), so the gain increases. Therefore, the CTLE has higher gain at high

As a result, the CTLE can compensate for high frequency component loss, and improve the signal quality at the receiver.

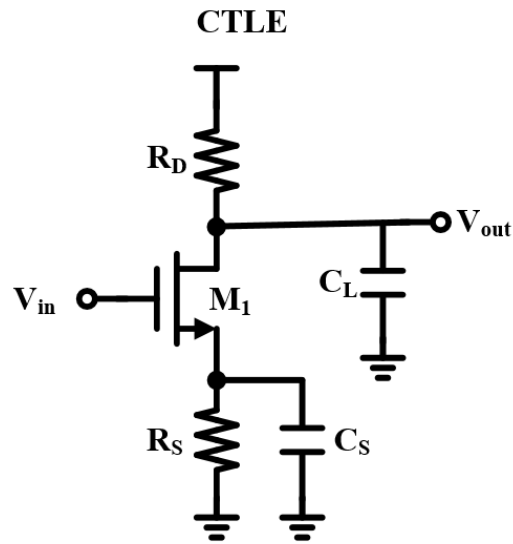

$$g_m = 38.5\text{mS}$$

$$R_s = 1.39\text{k}\Omega$$

$$C_s = 172.7\text{fF}$$

$$R_D = 0.58\text{k}\Omega$$

$$C_L = 200\text{fF}$$

Transfer Function is  $\frac{V_{out}}{V_{in}} = \frac{A_1(1 + \frac{\omega}{\omega_z})}{(1 + \frac{s}{\omega_{p1}})(1 + \frac{s}{\omega_{p2}})}$

$$\omega_{p1} < \omega_{p2}$$

$$\omega_{p1} = \text{_____ rad/s}$$

$$\omega_{p2} = \text{_____ rad/s}$$

$$\omega_z = \frac{\quad}{\quad} \text{rad/s}$$
$$A_1 = \frac{\quad}{\quad} V/V$$

As you can see, by suppressing the low-frequency components, we can relatively enhance part of the high-frequency components, which helps increase the overall system bandwidth.

*Correct Answers:*

- 25
- $8.792 \times 10^{10}$
- 1467
- 54.52
- $8.621 \times 10^9$
- $2.271 \times 10^{11}$
- $4.166 \times 10^9$
- -0.4096